

COMAV'S SLIDE GATE VALVE SGB is designed for your different aims as shut off the flow of product and to dose the product during the discharge

SGB thanks to a two opposite cylinders sets the dosing trough the double blades having always a free opening, moreover its compact design allows a wide application from outlets of dry bulk storage bins, silos, conveyors and other discharge points.

SGB twin blades is used where dust sealing is request, thank to self-calibrated spring that extend the service life by compensating for wear.

The slide gate valve meets the most demanding application on the market.

APPLICATIONS

GRAVIMETRIC FLOW

POWDER

GRANULE

PELLETS

DESIGN

SIZE: DN 200

BODY: ALUMINIUM

BLADE: STAINLESS STEEL AISI 304/316L

MAIN SEAL: NOVATRON

OPERATION: DOUBLE CYLINDER

FEATURES

PRESSURE: ATM, 1 BAR

TEMPERATURE: MAX 100 °C

RUGGED DESIGN

LONG LIFE



OPTIONALS

- SPECIAL EXECUTION FOR ABRASIVE PRODUCT
- FOOD GRADE APPROVED MATERIAL
- VARIOUS CHEMICAL TREATMENT ON BODY/FLAP
- VARIOUS SEAL MATERIAL
- HIGH TEMPERATURE VERSION
- CUSTOM SIZE

BROCHURE



COMPLIANCE



II 2/3DC T135*

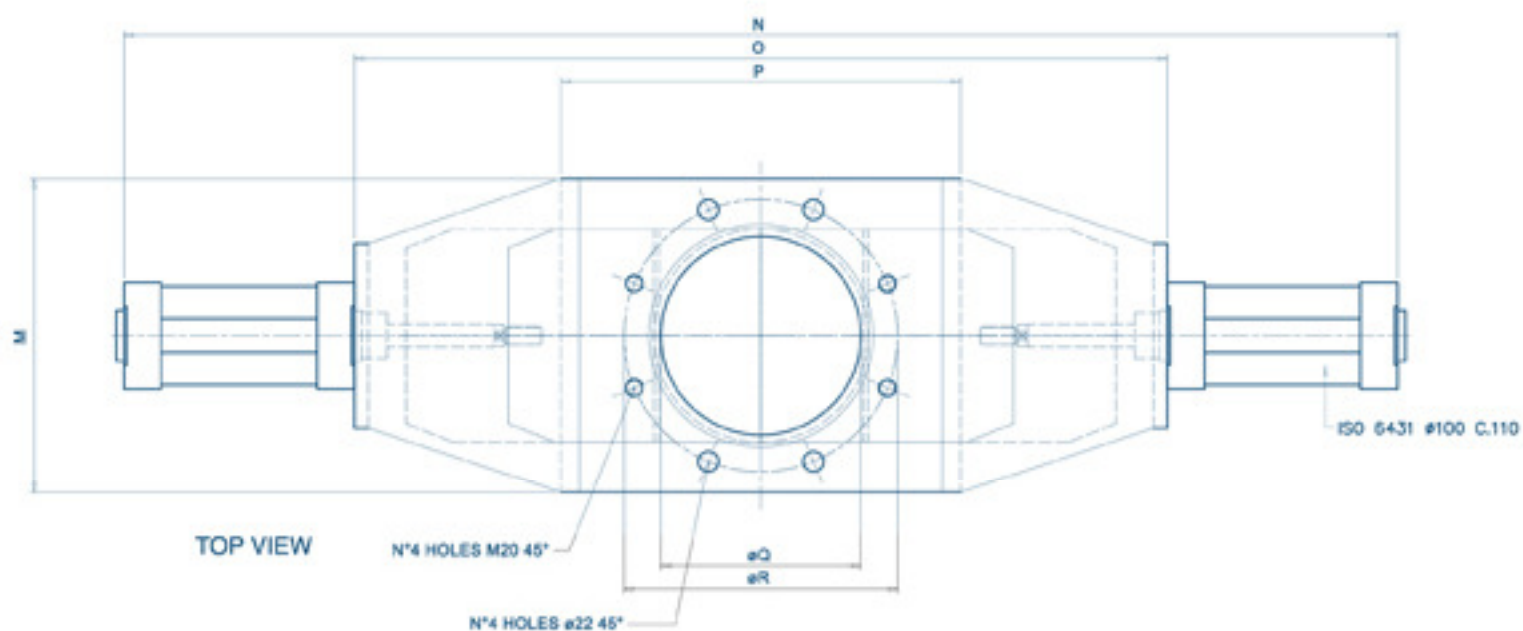
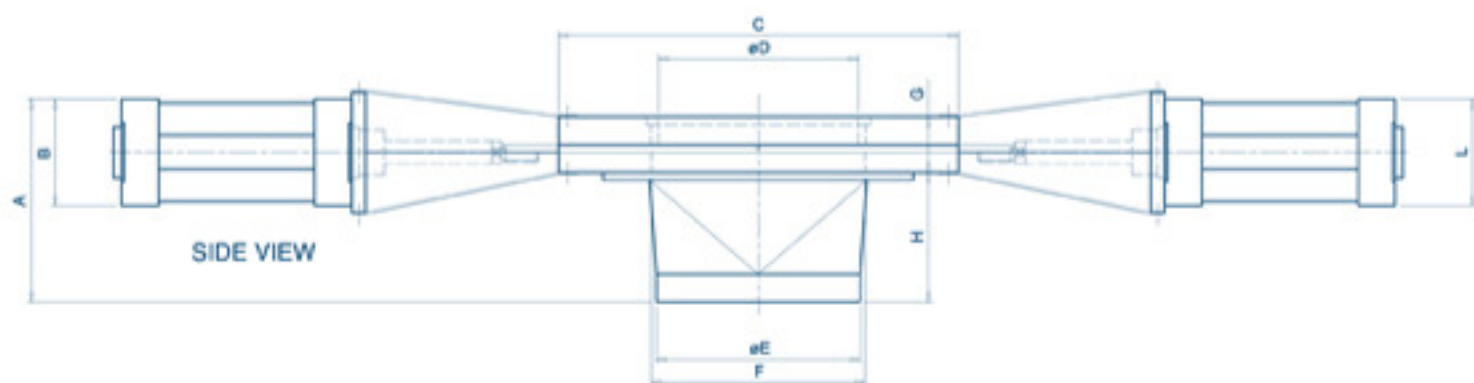

A	B	C	ØD	ØE	F	G	H	L	M	N	O	P	ØQ	ØR	
200	220	115	430	215	219,1	230X230	60	140	115	340	1370	875	430	215	295